



# Tungsten Carbide Dies

typical die geometries for various draw materials:

wire material	reduction $2\alpha$	bearing (%d)
high-carbon steel - steelcord	7° - 10°	20 - 40
CO <sub>2</sub> welding wire - copper plated	10° - 14°	30 - 40
low-carbon steel	10° - 12°	20 - 40
stainless steel	12° - 14°	30 - 50
copper	18° - 20°	30 - 40
aluminium	20° - 22°	30 - 40
brass	18° - 20°	30

TC standard nibs for wire drawing dies: (all sizes in mm)

size	nib (dn x hn)	d	TC grade *	casing (DxH)
I	9 x 6	0.1 - 1.2	RH3F	28 x 15
I	10 x 8	0.2 - 2.0	RH6F	28 x 22
II	12 x 10	0.3 - 2.5	RH6F	28 x 20 (43x27)
II	16 x 13	0.3 - 5.0	RH6F+RH6N	43 x 27 (28x20)
III	20 x 17	1.5 - 7.0	RH6F+RH6N	43 x 31 (43x27)
IV	25 x 20	3.8 - 9.0	RH6N	53 x 40 (43x31)
V	30 x 24	4.0 - 12	RH6N	63 x 40 (53x40)
VI	35 x 24	11 - 15	RH11N	80 x 40 (63x40)
VII	40 x 24	13.5 - 18	RH11N	100 x 40 (80x40)
VIII	45 x 24	17 - 21	RH11N	100 x 40 (80x40)

other nibs-sizes and casings on request

\* explanation: <http://www.redies.com/pdf/TCgrades.pdf>

## die profile for fine or plated wire, $d < 0.3$ mm

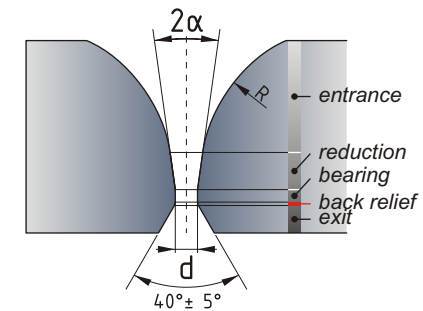

## standard profile

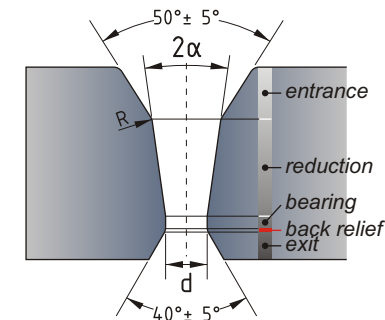

## casing geometry

